

THE

# General Radio EXPERIMENTER

VOLUME XXVIII No. 2

JULY, 1953

Copyright, 1953, General Radio Company, Cambridge, Mass., U. S. A.



ELECTRICAL MEASUREMENTS AND THEIR INDUSTRIAL APPLICATIONS®

## A SIMPLIFIED SYSTEM OF WAVE ANALYSIS FOR PRODUCTION TESTING

### Also IN THIS ISSUE

	Page
VARIAC CONTROL OF HEATERS.....	7
GENERAL RADIO AT WESCON 1953 ....	8

● **ALTHOUGH DESIGNED** principally for measuring distortion and noise in broadcast systems, the TYPE 1932-A Distortion and Noise Meter has also been found to be an indispensable laboratory tool for making quickly and accurately any adjustment that affects the distortion, hum, or noise output of communications apparatus.

Properly used, this instrument provides a rapid, visual, complete, and continuous analysis of the undesirable by-products appearing in the output of such equipment.

In the General Radio Standardizing Laboratory, the TYPE 1932-A is used for testing audio oscillators, amplifiers, power supplies, and, in conjunction with suitable demodulating equipment,<sup>1</sup> signal generators of all frequencies. It is also used as a voltage indicator in attenuator and filter measurements, as a null indicator for audio-frequency bridge work, and as a frequency meter. Because of its reliability and its ease of operation, it has, wherever applicable, completely supplanted other types of wave analyzing equipment.

<sup>1</sup>The TYPE 1931-A Modulation Meter is used from .5 to 60 megacycles, the TYPE 874-VR Voltmeter Rectifier plus a simple L-C filter at VHF and UHF.

Figure 1. Panel view of the Type 1932-A Distortion and Noise Meter.

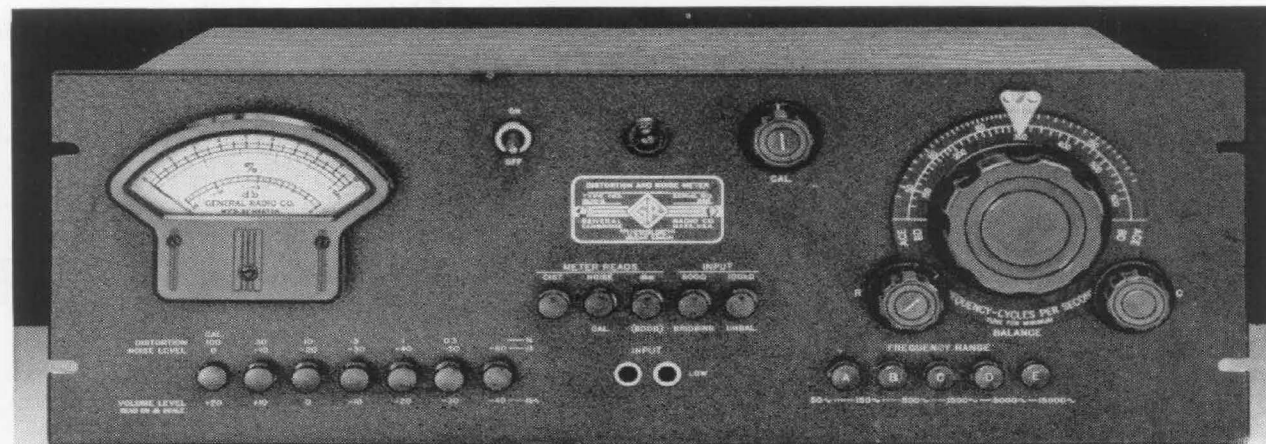

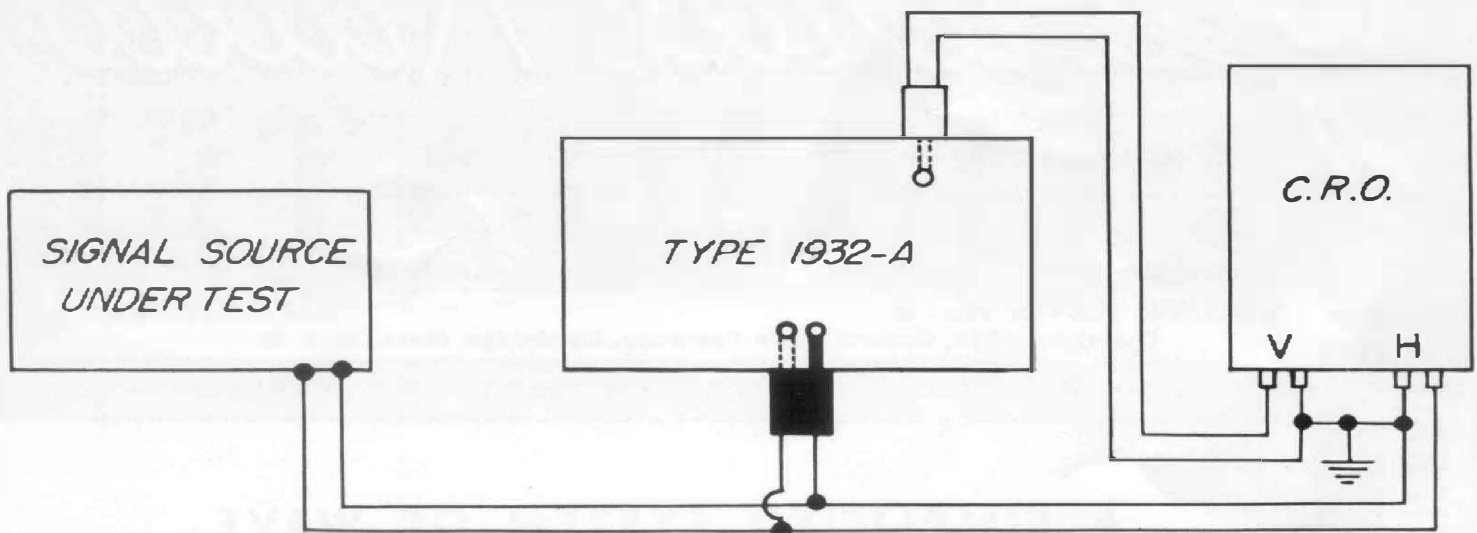

Figure 2. Test Setup for Visual Wave Analysis (top view).

The procedure is as follows: Set the signal source to any frequency in the range of 50 cycles to 15 kilocycles, and to any output within the range of 1.5 to 100 volts; calibrate the Type 1932-A, using its 100 K $\Omega$  input;<sup>2</sup> adjust the CRO gain controls to give a 1:1 Lissajous pattern (a diagonal line at most frequencies); cut in the null network of the Type 1932-A, and adjust it to eliminate the fundamental frequency component of the signal; set the push-button attenuator to give an on-scale meter indication. The distortion and noise by-products of the signal will now be presented graphically on the CRO in a form that can readily be analyzed, as well as being numerically summed up by the panel meter of the Type 1932-A.

<sup>2</sup>The 600-ohm input is a bridging (transformer) input, intended for broadcast use on program lines. It should be used only when a balanced input is required, for it restricts somewhat the frequency and distortion range of the instrument. It is not a matching network for 600-ohm systems.

The TYPE 1932-A Distortion and Noise Meter consists of a high-gain amplifier with an R-C interstage coupling unit that balances to a sharp null, a calibrated attenuator for adjusting the sensitivity, and a vacuum-tube voltmeter. The null network, which is continuously adjustable in frequency, eliminates the fundamental of the audio-frequency signal, and the distortion products that remain are indicated on the panel meter. The null network is switched out of the circuit for noise and hum measurements, so that the instrument operates as a highly sensitive voltmeter.

When the null network is tuned to the fundamental frequency of a signal in the frequency range of 50 cycles to 15 kilocycles, the meter indicates the *total* value of *all* by-products present: harmonics, hum, and noise. The simple expedient, however, of connecting an oscilloscope to plot these by-products versus the total input signal enables

the user to recognize, to evaluate, and, if necessary, to correct for whatever distortion or noise components happen to predominate. The only special skill required of the operator is the ability to recognize a few simple Lissajous patterns.

### ANALYSIS OF WAVE FORMS

The Lissajous pattern appearing on the CRO will contain two components, the one stationary, the other in motion. The stationary component comprises the distortion, stationary because of the synchronism between x-axis and y-axis signals; the moving component comprises the noise (usually hum), moving because a non-synchronous or random relationship exists.<sup>3</sup> In a given noise-distortion test, therefore, a glance at the CRO pattern immediately resolves the problem into either one of distortion or one of noise.

<sup>3</sup>In the special case where the signal itself is derived from, and harmonically related to, the power frequency, no distinction between hum and distortion can, of course, be made.



Assume the problem is one of distortion. Since this test procedure is limited to communications equipment, or rather to nominally sine-wave signals, the only harmonics that need be considered are the second and the third. The only Lissajous patterns, therefore, that enter into the analysis of the distortion, *regardless of the fundamental frequency involved*, are the simple 2:1 pattern, the simple 3:1 pattern, and various combinations of the two in which, generally, one or the other will predominate. Hence the principal skill required of one who uses this method of analysis is to be able to discern whether the Lissajous pattern is primarily 2:1 or 3:1. Having determined this (at a glance), he will know

what corrective action to take—whether to shift an operating point or bias (second harmonic), or to replace a component with limited dynamic range (third harmonic). Furthermore, the *total* effect of any such action will appear immediately. Typical distortion patterns are illustrated in Figure 3.

When the problem is primarily one of noise, the moving part of the pattern will be larger than the stationary part (see Figure 3). Where noise (hum) adjustments are provided, they can be set to minimize this component. Should analysis of the noise be desired, the horizontal axis of the CRO can be switched to the power frequency to “stop” the hum components (see Figure

**Figure 3.** Typical distortion and hum patterns. In each case the pattern on the left is produced with power-line-frequency synchronization, the pattern on the right with signal-frequency synchronization.

- (1) 5 kc fundamental  
Second harmonic 5 times third  
Negligible hum
- (2) 5 kc fundamental  
Second and third harmonics about equal  
Hum (second harmonic) about 10% of total
- (3) 5 kc fundamental  
Third harmonic 10 times second  
Negligible hum
- (4) Line-frequency hum predominant  
Distortion same as in (2) above  
This pattern was produced by introducing line voltage into the grid circuit of the oscillator under test

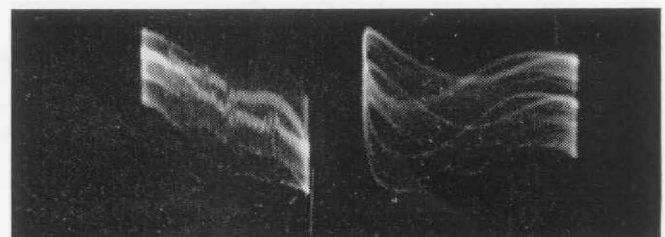
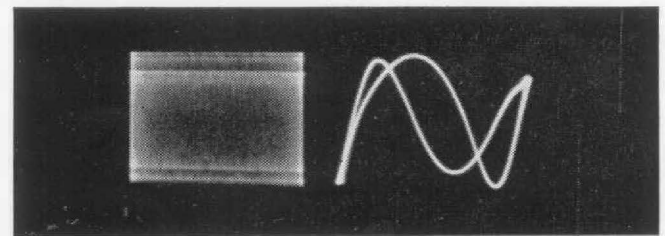
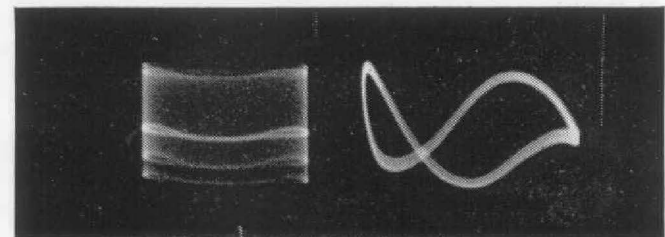
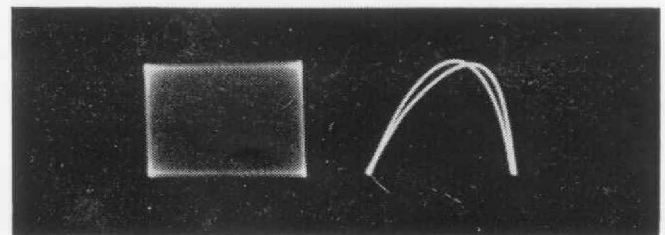

Figure 3 (continued on page 4)

3). If in a given problem both distortion and hum are appreciable factors, both horizontal axes can be supplied simultaneously by means of an electronic switch.

Thus a single setup, with one quick adjustment, supplies all the information required to adjust bias controls, drive controls, B+ voltages, hum-bucking controls, and any other variables that may affect the linearity and hum-content of the equipment under test. The effects

of such adjustments are monitored instantly, continuously, and completely. From the standpoint of speed as well as of thoroughness and accuracy, the system leaves little to be desired.

A serious limitation can occur when one attempts to measure very low values of distortion and noise, unless the normal test procedure is modified. The residual distortion and hum of the distortion meter itself can be as high as 0.1% on some ranges, if operated in the normal

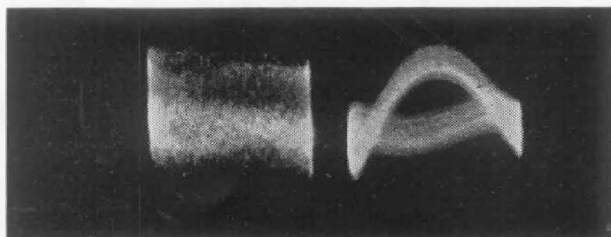
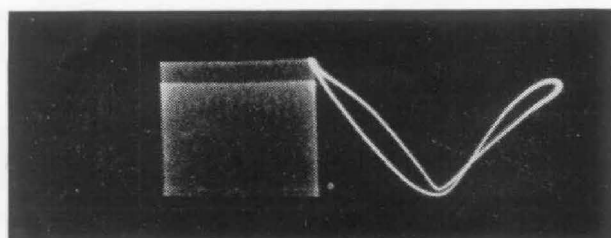
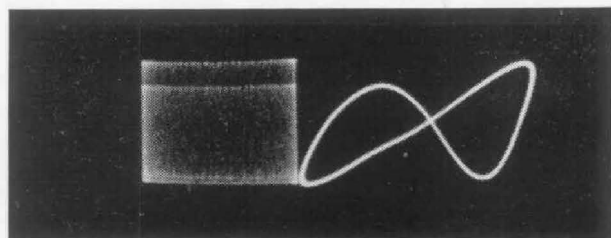
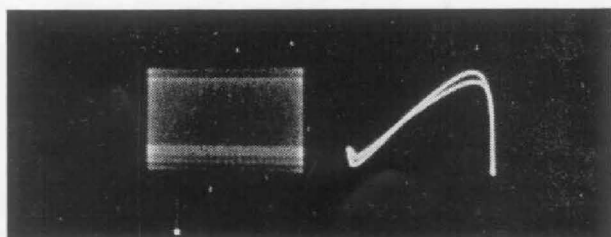
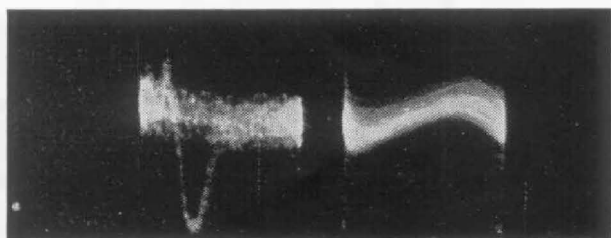

Figure 3 (continued)

- (5) 1 kc fundamental  
Power supply ripple predominates because plate voltage regulator is not functioning properly. Total distortion is 1.5%; third harmonic is twice second. Relative hum amplitudes are:

Frequency	60	120	180	240	300
Amplitude	100	100	60	80	50

- (6) 1 kc fundamental  
Second harmonic 8 times third  
Negligible hum

- (7) 1 kc fundamental  
Second harmonic 12 times third  
Negligible hum

- (8) Second harmonic 2 times third, plus higher-order harmonics

- (9) 1 kc fundamental  
All hum and distortion products about equal. This is the output of a TYPE 1301-A Low-Distortion Oscillator at optimum adjustment. Total noise and distortion at this frequency was 0.05%.



manner. Hence, in evaluating distortion and hum in the order of .5% or less, the user can be misled as to both the quantity and the nature of the undesired signal by-products. Means are provided on the distortion and noise meter, however, both to determine the magnitude of the residual voltages and to make them negligible as a factor in measurements of .1% or less.<sup>4</sup>

Residual hum (in the distortion-measuring circuit) causes a residual meter indication when no input signal is present, and is therefore easily recognized. It is most pronounced on the lowest frequency range and on the lowest (most sensitive) attenuator position. An adjustment is provided to minimize it, but it is still an important factor in making noise-distortion measurements of the order of .1% or less. To minimize error in analyzing the hum content of such signals, the hum should be evaluated at a signal frequency above 150 cycles, if possible, and with the TYPE 1932-A calibrated at its normal (1.5 volts) input level. In any event, whenever the distortion pattern exhibits a high hum content, the input signal should be disconnected momentarily to determine whether the hum is residual or is a signal by-product.

Residual distortion can be virtually eliminated simply by operating at a signal level 10 db below the 1.5-volt normal input. In practice, this consists merely of using a different attenuator setting from that normally used, and a corresponding meter scale. All General Radio TYPE 1301-A Low-Distortion Oscillators (rated at not more than .1% total distortion and noise) are tested by this method.

<sup>4</sup>The residual hum described here applies only to distortion measurements, because it is introduced in the distortion-measuring circuits of the TYPE 1932-A. In noise measurements, when the noise constitutes the total signal being measured, this circuit is not used, and consequently residual noise and hum are negligible (more than 80 db below zero dbm level).

A further limitation must be considered when measurements are attempted in the presence of r-f voltages, as in demodulated carrier signals, beat-frequency oscillator outputs, and the like. No provision for radio-frequency filtering is made in the TYPE 1932-A, and such filtering, if necessary, must be inserted ahead of the input. The same considerations apply as for any high-gain audio-frequency amplifier.

### SOME EXAMPLES OF USES OF VISUAL ANALYSIS

A typical example of the usefulness of this system of wave analysis is the laboratory adjustment of the TYPE 1302-A (R-C) Oscillator. In this instrument nineteen variables must be set correctly to give the desired operating conditions at all frequencies. To adjust them by conventional methods at one time required a great deal of painstaking, point-by-point analysis of circuit behavior. When the test procedure was modified to employ the visual-analysis system described above, it was quickly learned that all information necessary to make the adjustments appeared on the CRO distortion pattern at certain settings of the panel controls, and that adjustments optimized by eye (visual analysis), even without regard to the numerical values involved, always resulted in a level of performance that was well within specifications. Currently, using this method, the average test time on this instrument is half what it formerly was.

Even in the design and development field, this system has proved valuable. A recently developed audio oscillator incorporated a push-pull output circuit supplied by a direct-coupled driver. Conventional methods of wave analysis indicated that the circuit, as first set up,

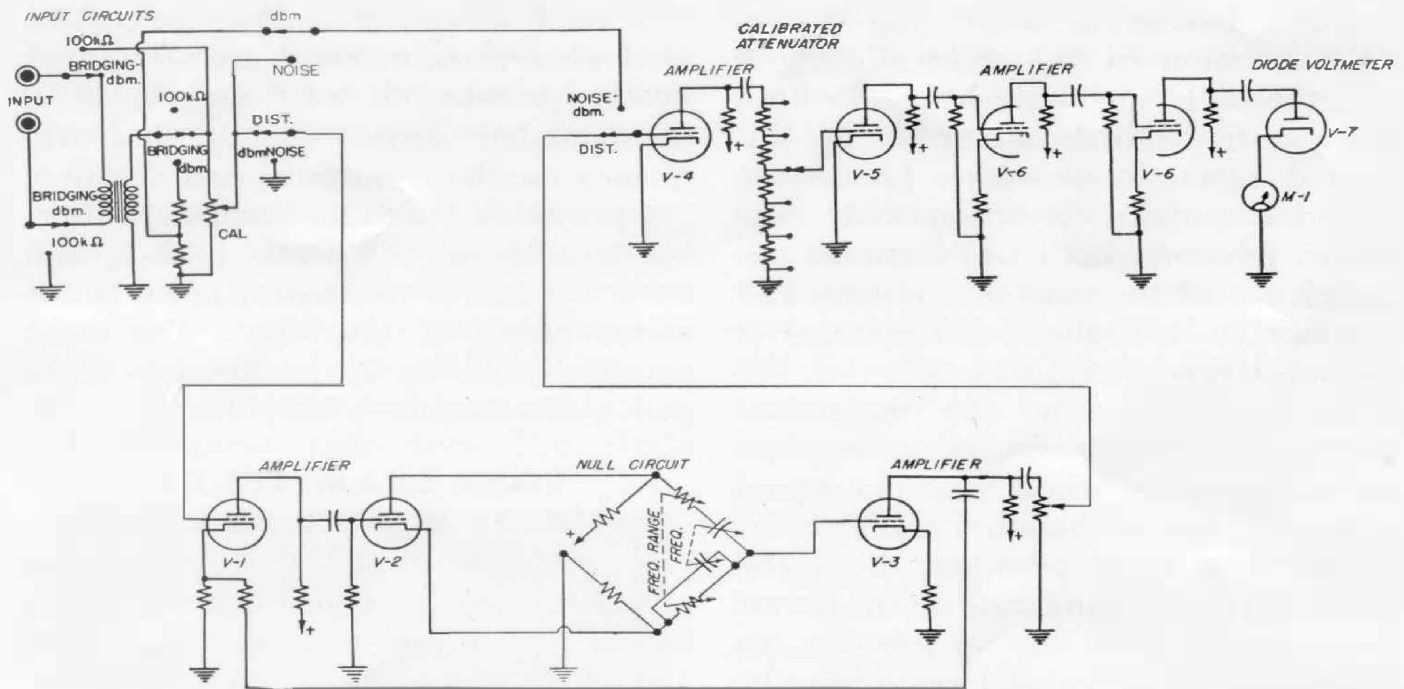

Figure 4. Elementary schematic circuit diagram of the distortion and noise meter.

would develop, at best, almost .5% distortion at rated output. Examination of the distortion by-products by visual analysis, however, indicated that something was wrong; to achieve *minimum* distortion required an abnormal, seriously unbalanced bias in the push-pull stage. Upon further investigation, a circuit error was located and corrected. The revised circuit developed rated output with greater efficiency and with less than half the distortion originally present. The conventional wave analysis had, of course, correctly measured the distortion of the original circuit, but had *failed to indicate optimum circuit conditions*.

**SO MUCH INFORMATION,  
SO FAST!**

To sum up, therefore:

The TYPE 1932-A Distortion and Noise Meter, when used in conjunction with a CRO so connected as to plot its output versus its input, supplies the

following useful information concerning a nominally sinusoidal signal supplied to it:

1. An approximately rms summation of the distortion and noise by-products of the signal, in per cent or in db below some reference.
2. A distinction between distortion and noise, immediately apparent to the eye.
3. A distinction between second harmonic and third harmonic distortion when one or the other predominates. Only two basic Lissajous patterns apply.
4. An indication of optimum conditions, whenever adjustments are made that affect distortion or noise.

When the x-axis of the CRO is switched to a voltage of line frequency, further information is supplied regarding the hum components present. If the x-axis switching is done continuously, as with an electronic switch, all of the above information is supplied instantly and continuously, as adjustments are made.



While precise numerical values of these various frequency components are not defined, their *relative* magnitudes are accurately portrayed. Wherever this

amount of information is adequate for the purposes at hand, as, for instance, in production testing, the system leaves little to be desired.

— W. P. BUUCK

## VARIAC CONTROL OF HEATERS

The Variac<sup>®</sup> autotransformer offers a convenient means of controlling the input to electrical heaters. The Variac circuit shown here can be used in automatic control to maintain constant tem-

perature in ovens and baths, and is particularly useful where an adjustable thermostat is used to obtain successive temperature settings.

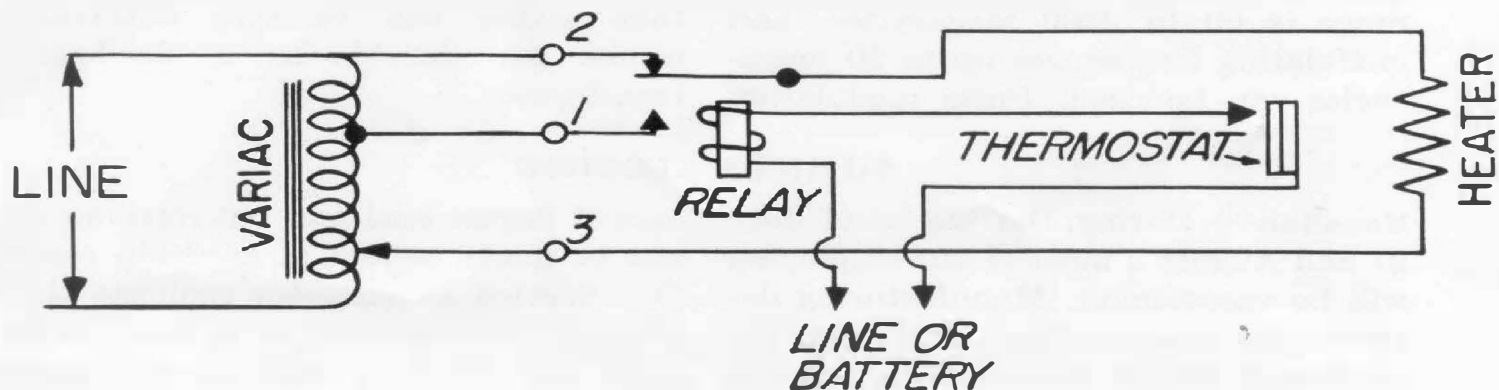

## MISCELLANY

**Papers** — By Harold B. Richmond, Chairman of the Board, General Radio Company: "Incentives as a Tool of Management," at the May 7 meeting of the Professional Group on Engineering Management, Washington, D. C., Section, Institute of Radio Engineers; and

"Patents and Licenses," at the Electronics Group Meeting, Scientific Apparatus Makers' Association, White Sulphur Springs, West Virginia, May 25. Since neither of these papers has been prepared for publication, copies are not available for distribution.



## GENERAL RADIO AT WESCON 1953

General Radio products will be on display in Booths 913 and 914 at the Western Electronic Show and Convention to be held in the Civic Auditorium, San Francisco, August 19, 20 and 21.

Among the General Radio instruments shown will be:

*Type 1217-A Unit Pulse Generator* — a small, compact, inexpensive generator of pulses, with rise time as short as 0.05 microsecond and repetition rates between 30 and 100,000 cps.

*Type 1000-P7 Balanced Modulator* — a crystal-diode modulator designed to operate on the output of standard-signal generators to produce 100% amplitude modulation without incidental frequency modulation. Carrier frequency range is 60 to 2500 megacycles, and modulating frequencies up to 20 megacycles can be used. Pulse modulation

can also be applied, with rise times as short as 0.02 microsecond.

*Limit bridges* for measuring d-c resistance and for comparing resistors, capacitors, and inductors at audio-frequencies.

*Sound-measuring equipment* — a complete line of sound-level meters, analyzers, and accessories for the measurement of noise and other sounds.

*Type 1602-B U-H-F Admittance Meter*, with a full line of accessories, set up to measure television transmitting antennas.

*Variac*<sup>®</sup> autotransformers with General Radio's new Duratrak contact surface that stands up under punishing overloads — an outstanding development that makes the variable autotransformer as durable as a fixed-ratio transformer.

### SUMMER CLOSING

**Vacation** — During the weeks of July 27 and August 3 most of our employees will be vacationing. Manufacturing departments will be closed, and other departments will be manned by a skeleton staff. Every effort will be made to take

care of urgent business, but repairs cannot be made, except in hardship cases. Our Service Department requests that shipments of material to be repaired be scheduled either to reach us well before this period or delayed until afterward.

## GENERAL RADIO COMPANY

275 MASSACHUSETTS AVENUE

CAMBRIDGE 39

MASSACHUSETTS

TELEPHONE: TRowbridge 6-4400

### BRANCH ENGINEERING OFFICES

NEW YORK 6, NEW YORK  
90 WEST STREET  
TEL.—WOrth 2-5837

LOS ANGELES 38, CALIFORNIA  
1000 NORTH SEWARD STREET  
TEL.—HOLlywood 9-6201

CHICAGO 5, ILLINOIS  
920 SOUTH MICHIGAN AVENUE  
TEL.—WAbash 2-3820

### REPAIR SERVICES

#### WEST COAST

WESTERN INSTRUMENT CO.  
826 NORTH VICTORY BOULEVARD  
BURBANK, CALIFORNIA  
TEL.—ROckwell 9-3013

#### CANADA

BAYLY ENGINEERING, LTD.  
5 FIRST STREET  
AJAX, ONTARIO  
TEL.—Toronto WA-6866